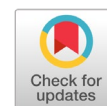


Analysis of color features performance using support vector machine with multi-kernel for batik classification



Edy Winarno ^{a,1}, Wiwien Hadikurniawati ^{a,2}, Anindita Septiarini ^{b,3,*}, Hamdani Hamdani ^{b,4}

^a Faculty of Information Technology, Universitas Stikubank, Semarang, Indonesia

^b Department of Informatics, Faculty of Engineering, Mulawarman University, Samarinda, Indonesia

¹ edywin@edu.unisbank.ac.id; ² wiwien@edu.unisbank.ac.id; ³ anindita@unmul.ac.id; ⁴ hamdani@unmul.ac.id

* corresponding author

ARTICLE INFO

ABSTRACT

Article history

Received April 8, 2022

Revised June 26, 2022

Accepted June 30, 2022

Available online July 31, 2022

Keywords

Feature Extraction

Color moment

YIQ

SVM

Cross Validation

Batik is a sort of cultural heritage fabric that originated in many areas of Indonesia. It can be traced back to many different parts of Indonesia. Each region, particularly Semarang in Central Java, Indonesia, has its Batik design. Unfortunately, due to a lack of knowledge, not all residents can recognize the types of Semarang batik. Therefore, this study proposed an automated method for classifying Semarang batik. Semarang batik was classified into five categories according to this method: Asem Arang, Blekok Warak, Gambang Semarang, Kembang Sepatu, and Semarangan. It is required to analyze the color features based on the color space to develop discriminative features since color was able to differentiate these batik patterns. Color features were produced based on the RGB, HSV, YIQ, and YCbCr color spaces. Four different kernels were used to feed these features into the Support Vector Machine (SVM) classifier: linear, polynomial, sigmoid, and radial basis functions. The experiment was carried out using a local dataset of 1000 batik images classified into five classes (each class contains 200 images). A cross-validation test with a k-fold value of 10 was performed to analyze the method. In each of the SVM Kernels, the results showed that the proposed method achieved an accuracy value of 100% by utilizing the YIQ color space, which was reliable throughout all the tests.



This is an open access article under the [CC-BY-SA](https://creativecommons.org/licenses/by-sa/4.0/) license.



1. Introduction

Indonesia is a country with a diverse cultural heritage, especially related to traditional fabrics originating from various regions. Sarong and Batik are traditional fabrics from Indonesia. Since its inception, Batik has continued to expand in popularity within Indonesian society [1]. Moreover, Batik was inscribed on UNESCO's global cultural heritage sites list in 2009 as the Indonesian state's identity [2]. Batik is now used for regional celebrations and uniforms for institutions and events across the globe. Even Batik has evolved into a fashion trend that may be seen in a variety of professional and informal settings throughout one's daily life. The presence of a specific theme distinguishes Batik from distinct regions. The batik themes found in the province of Central Java, particularly in the city of Semarang, are diverse and one-of-a-kind.

Semarang batik has an identity of patterns and motifs that highlight the characteristics and icons of the city of Semarang. The Semarang Batik motif is marked by the appearance of the Tugu Muda motif,

the Lawang Sewu building, and other historical buildings, followed by additional ornaments in the form of flora and fauna motifs like Peacocks, Roses, Storks, Blekok birds, Tamarind fruit. In addition, the hallmark of Semarang batik is the indentation at the bottom of the fabric. Another characteristic of Batik Semarang is related to coloring; it has a variety of colors for different types of Batik, with colors that tend to be dark. The diversity of motifs and colors causes people to be unable to recognize the types of Semarang Batik due to a lack of knowledge. Therefore, an automatic method for Semarang batik classification was needed.

The studies related to the classification of Semarang Batik are still limited. However, several previous studies related to the classification of Batik based on image processing have been developed. This study consisted of three main processes: pre-processing, feature extraction, and classification, as in [3]–[9]. Scaling and rotating of images are performed by pre-processing, followed by feature extraction using the multiwindow and multiscale extended center symmetric local binary patterns (MU2ECS-LBP) algorithms. The classification method utilized k-nearest neighbor (KNN) and artificial neural networks (ANN). The experiment results indicated that the MU2ECS-LBP algorithm implementation attained optimal performance, with a 99% accuracy value [10]. Meanwhile, batik detection using ANN has employed texture characteristics based on the Gray Level Co-occurrence Matrix (GLCM) technique. The backpropagation algorithm compared the Scaled conjugate gradient (trainscg) and Levenberg-Marquardt algorithm training methods (trainlm). The results indicated the accuracy acquired by training with the Scaled conjugate gradient (trainscg) algorithm was 84.12% greater than that obtained by training with the Levenberg-Marquardt (trainlm) algorithm of 86.11% [11].

The nonlinear mapping between design parameters and visual cognitive image (VCI) values have been modeled using pattern design based on shape grammar features and an ANN as a classifier. The genetic algorithm (GA) was used to optimize the three-layer ANN model to optimize the composition and produce new patterns of their VCIs. Experiments on the generative design of bronze drum patterns with considerable ethnic and religious significance established and validated the workflow and effectiveness of the offered method. The experimental results were demonstrated by predicting composition VCI values, providing an optimal parameter solution, and decompiling conceptual prototypes from pattern structures that properly satisfy consumers' visual cognitive needs [12]. Texture features were derived from GLCM, and color features were extracted from each channel of RGB color space. The acquired results had a precision of 90.66%, a recall of 94%, and an accuracy of 94%. Additionally, the Bag of Features (BOF) combination classified batik images using a Scale Invariant Feature Transform (SIFT) and an SVM classification. The experiment achieved a classification accuracy of 97.67% for unrotated Batik images, 95.47% for rotated Batik images, and 79% for scaled Batik images [13].

Bomba traditional textiles had to be classified using data classification to determine the motif of each Bomba textile pattern and place it in the appropriate class. The textural characteristic of the Bomba textile motif was used to categorize it. The GLCM method was used to extract texture features from the texture data. It was then decided to employ the Bomba textile pattern to incorporate textural features using the Quadratic Support Vector Machine (QSVM) approach. Single texture features improve the accuracy of the classification model by combining all of the features from all possible angles. An accurate motif classification model for the Bomba textile was constructed in this study, and the model had a classification accuracy of 94.6% and an error rate of 5.4% [14].

Previous studies have performed many efforts to develop the Batik classification. However, it is still challenging because the features utilized may not be selective, and the illumination regularly influences

the Batik image feature extraction outcomes. This study aims to investigate the color features of the Batik Semarang classification. The Semarang Batik was divided into five classes: Asem Arang, Blekok Warak, Gambang Semarangan, Kembang Sepatu, and Semarangan. The main contributions of this study are:

- The color features were extracted in four color spaces, including RGB, HSV, YIQ, and YCbCr, to get the most discriminatory features.
- The features were fed into the SVM classifier using four kernels (linear, polynomial, sigmoid, and Radial Basis Function) to produce optimal method performance.

The remainder of the paper is structured as follows. Section 2 discusses the classification approach proposed for Semarang Batik, covering the dataset used in this study, pre-processing, feature extraction, classification, and the performance evaluation method. Based on the experiments, Section 3 discusses the performance results of the proposed method. Section 4 is the conclusion of the paper.

2. Method

Specifically, this study aimed to analyze color features to determine the most discriminatory features to develop a robust classification method for Semarang Batik. Training and testing are the two phases of the proposed method. Pre-processing, feature extraction, and classification were the three main processes in both steps. The proposed method, which divides Batik Semarang into five classes: Asem Arang, Blekok Warak, Gambang Semarangan, Kembang Sepatu, and Semarangan, is represented in Fig. 1. The performance evaluation was subjected to assess the proposed method's robustness.

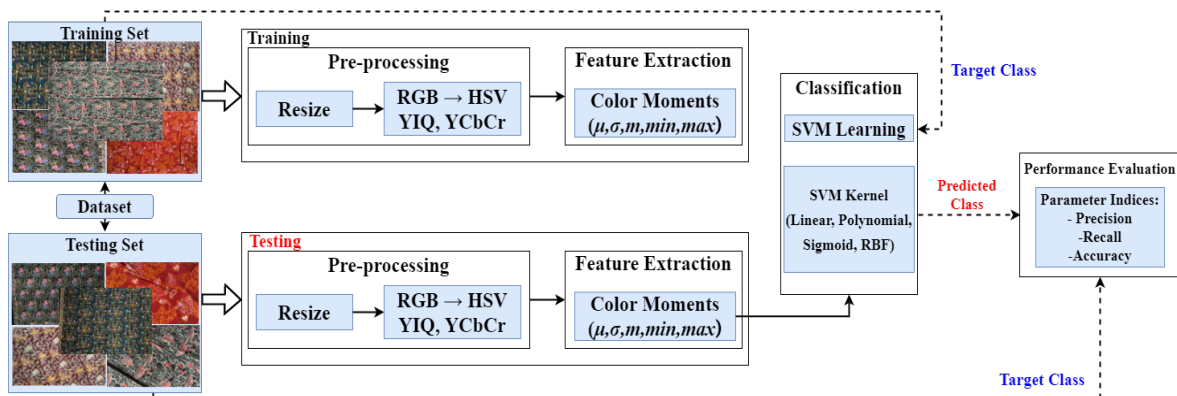


Fig. 1. The main processes of the proposed method for Semarang Batik classification

2.1. Semarang Batik Dataset

There are five distinct types of Semarang Batik in the dataset, which are as follows: Asem Arang, Blekok Warak, Gambang Semarangan, Kembang Sepatu, and Semarangan. Each class comprises 200 images, resulting in a total of 1000 images included in the dataset. The Batik fabric was captured with an integrated camera on an iPhone 6s in a well-lit indoor space for all images. With the camera perpendicular to the item, the distance between the camera and the object ranged from 30 to 60 cm. The Batik images were stored in JPEG format with a resolution of 3024×4032 pixels. The image example of the Semarang Batik dataset is depicted in Fig. 2.

2.2. Pre-processing

The first step in this process was to reduce the size of the original image from 3024×4032 pixels to 256×256 pixels [11] to lessen time. Subsequently, the RGB color space was converted to the HSV, YIQ, and YCbCr color spaces to produce the highest classification optimal results. RGB is a broad color space employed in the study related to the classification of Batik. On the other hand, previous studies have used various color spaces, such as HSV, YIQ, and YCbCr. While utilizing these color spaces, a conversion process based on the values in the RGB color space was required, which is defined in Equations (1) - (7) [15]–[17]. The sample image was resized and converted to RGB to HSV, YIQ, and YCbCr color space is shown in Fig. 3.

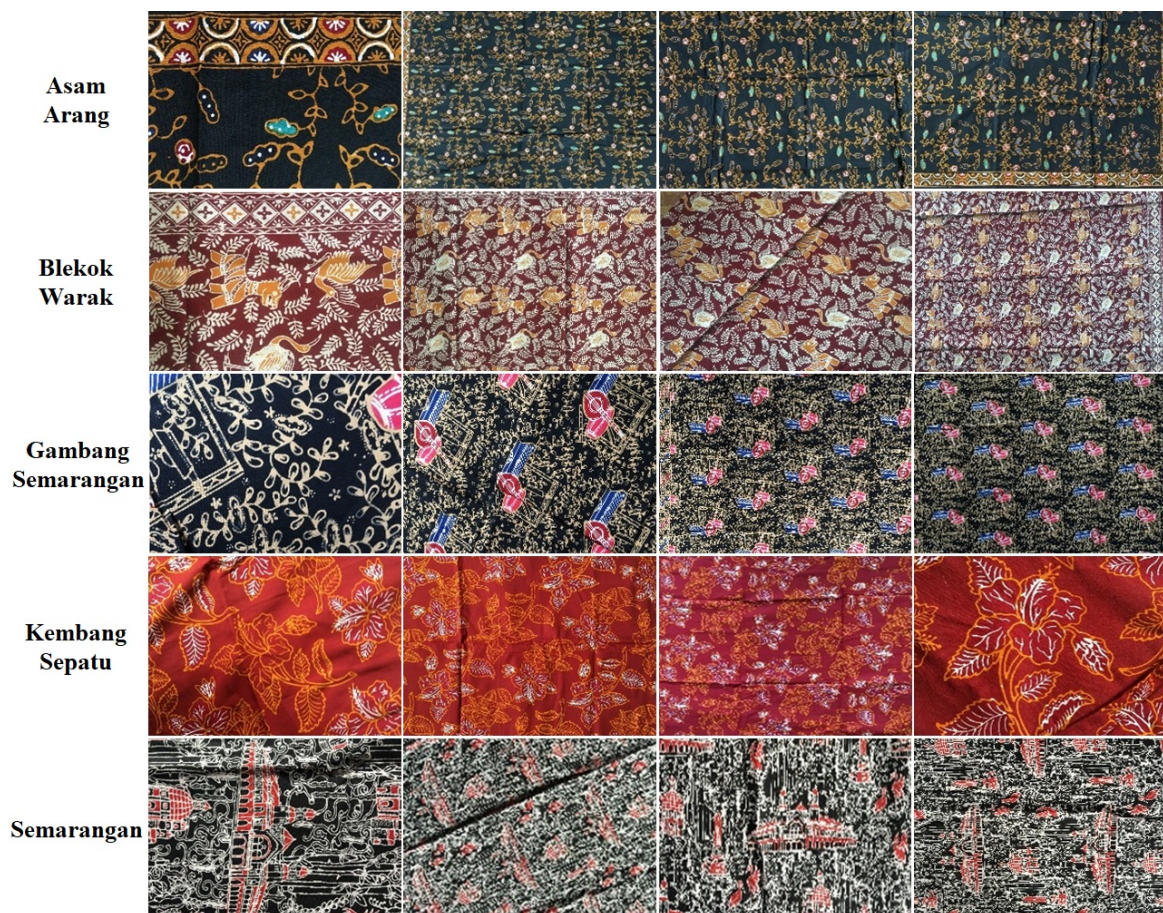


Fig. 2. The images example of the Semarang Batik dataset in various distances and angles

2.2.1. Convert RGB to HSV color spaces

The following steps are followed to convert RGB to HSV color spaces,

Step 1:

The RGB values should be normalized from 0...1 to 0...255:

$$R' = \frac{R}{255}, G' = \frac{G}{255}, B' = \frac{B}{255} \quad (1)$$

Step 2: Compute,

$$Cmax = \max(R', G', B') \text{ and } Cmin = \min(R', G', B') \quad (2)$$

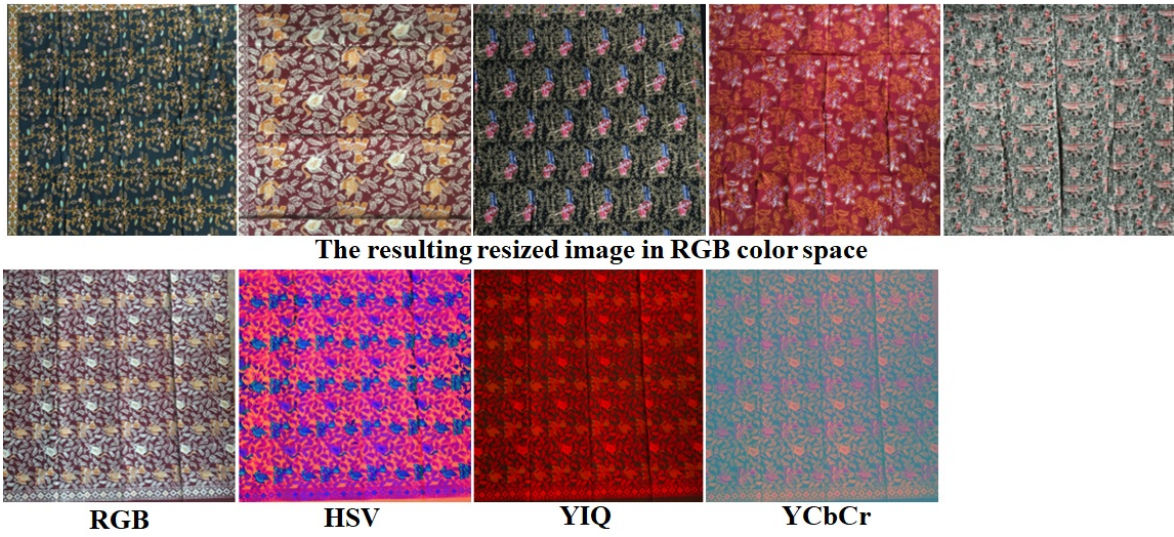


Fig. 3. The pre-processing image results: (a) resized image in RGB color space and (b) color space conversion.

Step 3:

$$\Delta = Cmax - Cmin \quad (3)$$

$$Hue = \begin{cases} 60^\circ \times \left(\frac{G' - B'}{\Delta} \text{ mod } 6 \right), Cmax = R' \\ 60^\circ \times \left(\frac{B' - R'}{\Delta} + 2 \right), Cmax = G' \\ 60^\circ \times \left(\frac{R' - G'}{\Delta} + 4 \right), Cmax = B' \end{cases} \quad (4)$$

Step 4: Saturation

$$S = \begin{cases} 0, Cmax = 0 \\ \frac{\Delta}{Cmax}, Cmax \neq 0 \end{cases} \quad (5)$$

Step 5: Value

$$V = Cmax$$

2.2.2. Convert RGB to YcBcR color spaces

$$\begin{bmatrix} Y \\ cB \\ cR \end{bmatrix} = \begin{bmatrix} 0.2568 & 0.5041 & 0.0979 \\ -0.1482 & -0.2910 & 0.4392 \\ 0.4932 & -0.3678 & -0.0714 \end{bmatrix} \begin{bmatrix} R \\ G \\ B \end{bmatrix} + \begin{bmatrix} 6 \\ 128 \\ 128 \end{bmatrix} \quad (6)$$

2.2.3. Convert RGB to YIQ color spaces

$$\begin{bmatrix} Y \\ I \\ Q \end{bmatrix} = \begin{bmatrix} 0.299 & 0.587 & 0.114 \\ 0.596 & -0.274 & -0.322 \\ 0.211 & -0.523 & 0.312 \end{bmatrix} \begin{bmatrix} R \\ G \\ B \end{bmatrix} \quad (7)$$

2.3. Feature Extraction

In this study, the color could be a robust descriptor to distinguish five types of Semarang Batik patterns due to the dissimilarities in intensity distribution. Therefore, the color feature is applied using a color moment which consists of analyzing the most suitable color space as a descriptor of the value of mean (μ), the standard deviation (σ), median (m), the minimum (\min), and maximum (\max). Color moments are used because they have been successfully applied in previous studies regarding classification cases [17], [18]. These features are extracted on each channel in four color spaces, including RGB, HSV, YIQ, and YCbCr, to select the optimal color space to use as a description. A total of 60 features were generated in this study. The color moments features were calculated using Equation (8) – (12) [19].

$$\mu_i = \sum_j^N = 1 \frac{1}{N} p_{ij} \quad (8)$$

where N is the number of pixels in the image and p_{ij} denotes the value of the j^{th} pixel of the image at the i^{th} color channel.

$$\sigma = \sqrt{\left(\frac{1}{N} \sum_j^N = 1 (p_{ij} - \mu_i)^2\right)} \quad (9)$$

where μ_i is the mean value for i^{th} color channel.

$$m = x + \left(\frac{f - f_{ii}}{f_i}\right) p \quad (10)$$

$$\min = \min (I) \quad (11)$$

$$\max = \max (I) \quad (12)$$

where I the intensity value of the pixels. The \min value indicates the lowest value of the color channel; otherwise, the \max value indicates the highest value of the color channel. The example of feature extraction from each type of Batik and color spaces is shown in Fig. 4.

2.4. Classification

The multi-class SVM method was used in this study due to its resilience in solving a variety of scenarios [14], [18]–[22]. The SVM classifier's primary goal is to get the $f(x)$ function that specifies the ideal hyperplane, which is as heterogeneous as the zones of various classes [19]. As illustrated in Fig. 5, the hyperplane was detected when it successfully differentiated two or more classes of input data points. Data points of both types are represented by M , which is the distance from the hyperplane to the closest point. To increase the M 's range, the following will be defined [23]:

$$\min \frac{\|w\|^2}{2} \text{ s. t. } \forall n. y_n (\langle w, x_n \rangle + b) \geq 1 \quad (13)$$

where a vector w defines the boundary, and the integer n indicates the number of inputs to the SVM. While x_n is the input data point and b is a scalar threshold value. The optimal hyperplane problem SVM, $f(x)$:

$$f(x) = \sum_{n=1}^t y_n a_n \langle x_n, x \rangle + b \quad (14)$$

x_n is the support vector having non-zero Lagrange multiplier a_n , and it should be us $a_n \geq 0$.

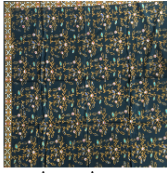

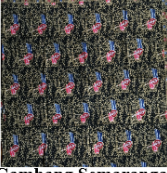


Dataset	RGB	HSV	YIQ	YCbCr
 Asem Arang	$-\mu R = 0,773$ $-\mu G = 0,740$ $-\mu B = 0,695$ $-\sigma R = 0,503$ $-\sigma G = 0,434$ $-\sigma B = 0,423$ $-mR = 76$ $-mG = 74$ $-mB = 68$ $-minR = 0$ $-minG = 0$ $-minB = 0$ $-maxR = 244$ $-maxG = 255$ $-maxB = 255$	$-\mu H = 0,324$ $-\mu S = 0,217$ $-\mu V = 0,323$ $-\sigma H = 0,235$ $-\sigma S = 0,154$ $-\sigma V = 0,198$ $-mH = 0,200$ $-mS = 0,170$ $-mV = 0,318$ $-minH = 0$ $-minS = 0$ $-minV = 0$ $-maxH = 0,998$ $-maxS = 1$ $-maxV = 1$	$-\mu Y = 0,292$ $-\mu I = 0,014$ $-\mu Q = -0,002$ $-\sigma Y = 0,173$ $-\sigma I = 0,501$ $-\sigma Q = 0,026$ $-mY = 0,292$ $-mI = 0,008$ $-mQ = -0,008$ $-minY = 0$ $-minI = -0,177$ $-minQ = -0,043$ $-maxY = 0,987$ $-maxI = 0,347$ $-maxQ = 0,201$	$-\mu Y = 800$ $-\mu Cb = 125$ $-\mu Cr = 129$ $-\sigma Y = 380$ $-\sigma Cb = 681$ $-\sigma Cr = 914$ $-mY = 80$ $-mCb = 125$ $-mCr = 128$ $-minY = 16$ $-minCb = 104$ $-minCr = 106$ $-maxY = 232$ $-maxCb = 104$ $-maxCr = 106$
 Blekok Warak	$-\mu R = 0,102$ $-\mu G = 0,939$ $-\mu B = 0,890$ $-\sigma R = 0,637$ $-\sigma G = 0,537$ $-\sigma B = 0,484$ $-mR = 95$ $-mG = 90$ $-mB = 83$ $-minR = 0$ $-minG = 0$ $-minB = 0$ $-maxR = 255$ $-maxG = 255$ $-maxB = 255$	$-\mu H = 0,331$ $-\mu S = 0,219$ $-\mu V = 0,422$ $-\sigma H = 0,272$ $-\sigma S = 0,148$ $-\sigma V = 0,244$ $-mH = 0,148$ $-mS = 0,196$ $-mV = 0,390$ $-minH = 0$ $-minS = 0$ $-minV = 0$ $-maxH = 0,998$ $-maxS = 1$ $-maxV = 1$	$-\mu Y = 0,375$ $-\mu I = 0,025$ $-\mu Q = 0,007$ $-\sigma Y = 0,214$ $-\sigma I = 0,065$ $-\sigma Q = 0,033$ $-mY = 0,362$ $-mI = 0,017$ $-mQ = -0,055$ $-minY = 0$ $-minI = -0,229$ $-minQ = -0,047$ $-maxY = 1$ $-maxI = 0,390$ $-maxQ = 0,225$	$-\mu Y = 982$ $-\mu Cb = 124$ $-\mu Cr = 131$ $-\sigma Y = 470$ $-\sigma Cb = 897$ $-\sigma Cr = 117$ $-mY = 96$ $-mCb = 124$ $-mCr = 130$ $-minY = 16$ $-minCb = 103$ $-minCr = 103$ $-maxY = 235$ $-maxCb = 103$ $-maxCr = 103$
 Gambang Semarang	$-\mu R = 0,921$ $-\mu G = 0,850$ $-\mu B = 0,840$ $-\sigma R = 0,696$ $-\sigma G = 0,593$ $-\sigma B = 0,520$ $-mR = 79$ $-mG = 73$ $-mB = 75$ $-minR = 0$ $-minG = 0$ $-minB = 0$ $-maxR = 255$ $-maxG = 255$ $-maxB = 255$	$-\mu H = 0,398$ $-\mu S = 0,255$ $-\mu V = 0,391$ $-\sigma H = 0,273$ $-\sigma S = 0,176$ $-\sigma V = 0,261$ $-mH = 0,500$ $-mS = 0,212$ $-mV = 0,333$ $-minH = 0$ $-minS = 0$ $-minV = 0$ $-maxH = 0,998$ $-maxS = 1$ $-maxV = 1$	$-\mu Y = 0,341$ $-\mu I = 0,017$ $-\mu Q = 0,046$ $-\sigma Y = 0,236$ $-\sigma I = 0,069$ $-\sigma Q = 0,034$ $-mY = 0,300$ $-mI = 0,042$ $-mQ = -0,081$ $-minY = 0$ $-minI = -0,252$ $-minQ = -0,048$ $-maxY = 1$ $-maxI = 0,380$ $-maxQ = 0,233$	$-\mu Y = 907$ $-\mu Cb = 126$ $-\mu Cr = 131$ $-\sigma Y = 516$ $-\sigma Cb = 957$ $-\sigma Cr = 124$ $-mY = 82$ $-mCb = 127$ $-mCr = 128$ $-minY = 16$ $-minCb = 104$ $-minCr = 100$ $-maxY = 235$ $-maxCb = 104$ $-maxCr = 100$
 Kembang Sepatu	$-\mu R = 0,927$ $-\mu G = 0,860$ $-\mu B = 0,857$ $-\sigma R = 0,707$ $-\sigma G = 0,607$ $-\sigma B = 0,532$ $-mR = 73$ $-mG = 71$ $-mB = 75$ $-minR = 0$ $-minG = 0$ $-minB = 0$ $-maxR = 255$ $-maxG = 255$ $-maxB = 255$	$-\mu H = 0,403$ $-\mu S = 0,260$ $-\mu V = 0,397$ $-\sigma H = 0,274$ $-\sigma S = 0,179$ $-\sigma V = 0,264$ $-mH = 0,555$ $-mS = 0,214$ $-mV = 0,345$ $-minH = 0$ $-minS = 0$ $-minV = 0$ $-maxH = 0,998$ $-maxS = 1$ $-maxV = 1$	$-\mu Y = 0,345$ $-\mu I = 0,016$ $-\mu Q = 0,052$ $-\sigma Y = 0,241$ $-\sigma I = 0,078$ $-\sigma Q = 0,342$ $-mY = 0,290$ $-mI = -0,377$ $-mQ = 0,020$ $-minY = 0$ $-minI = -0,262$ $-minQ = -0,047$ $-maxY = 1$ $-maxI = 0,387$ $-maxQ = 0,222$	$-\mu Y = 915$ $-\mu Cb = 126$ $-\mu Cr = 130$ $-\sigma Y = 527$ $-\sigma Cb = 991$ $-\sigma Cr = 124$ $-mY = 80$ $-mCb = 128$ $-mCr = 16$ $-minY = 103$ $-minCb = 99$ $-minCr = 100$ $-maxY = 235$ $-maxCb = 103$ $-maxCr = 99$
 Semarang	$-\mu R = 0,927$ $-\mu G = 0,860$ $-\mu B = 0,856$ $-\sigma R = 0,706$ $-\sigma G = 0,607$ $-\sigma B = 0,531$ $-mR = 77$ $-mG = 72$ $-mB = 76$ $-minR = 0$ $-minG = 0$ $-minB = 0$ $-maxR = 255$ $-maxG = 255$ $-maxB = 255$	$-\mu H = 0,408$ $-\mu S = 0,261$ $-\mu V = 0,396$ $-\sigma H = 0,274$ $-\sigma S = 0,175$ $-\sigma V = 0,265$ $-mH = 0,548$ $-mS = 0,214$ $-mV = 0,338$ $-minH = 0$ $-minS = 0$ $-minV = 0,007$ $-maxH = 0,998$ $-maxS = 1$ $-maxV = 1$	$-\mu Y = 0,345$ $-\mu I = 0,016$ $-\mu Q = 0,052$ $-\sigma Y = 0,241$ $-\sigma I = 0,078$ $-\sigma Q = 0,342$ $-mY = 0,290$ $-mI = 0,024$ $-mQ = 0,039$ $-minY = 0$ $-minI = -0,260$ $-minQ = -0,047$ $-maxY = 1$ $-maxI = 0,384$ $-maxQ = 0,222$	$-\mu Y = 901$ $-\mu Cb = 126$ $-\mu Cr = 131$ $-\sigma Y = 520$ $-\sigma Cb = 102$ $-\sigma Cr = 131$ $-mY = 78$ $-mCb = 128$ $-mCr = 128$ $-minY = 17$ $-minCb = 104$ $-minCr = 95$ $-maxY = 235$ $-maxCb = 104$ $-maxCr = 95$

Fig. 4. The example of feature extraction result

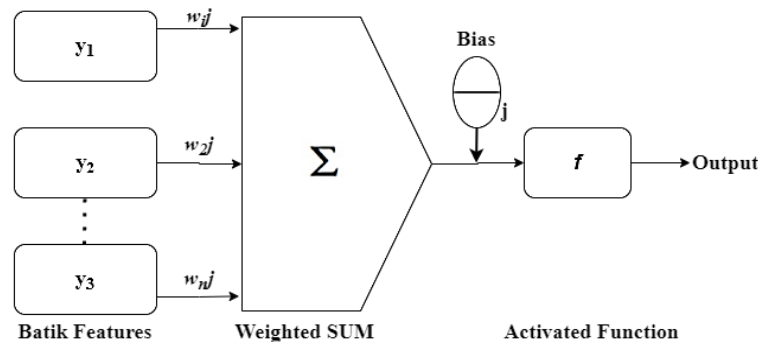


Fig. 5. An overview of the classification process using the SVM method

In order to maintain a manageable computing load, SVM methods arrange their mappings in such a way that dot products can be efficiently computed regarding the parameters in the high dimensional space by specifying them in terms of a kernel function $k(x, y)$ chosen for the issue. Linear, polynomial, sigmoid, or radial basis functions can be used as kernels. Several common kernels (K) are as follows [24]:

- Linear Function

$$K(x, x_i) = x^T x_i + r \quad (15)$$

- Polynomial Function

$$K(x, x_i) = (\gamma x^T x_i + r)^\rho, \gamma > 0 \quad (16)$$

- Sigmoid Function

$$K(x, x_i) = \tanh(\gamma x^T x_i + r) \quad (17)$$

- Radial Basis Function

$$K(x, x_i) = \exp(-\gamma \|x - x_i\|^2), \gamma > 0 \quad (18)$$

The application of kernel functions is designed to transform data into a more complex three-dimensional environment. Specifically, it operates on the closest points separating the hyperplane's points in this example.

2.5. Performance Evaluation

The performance evaluation of the proposed method was employed by applying the feature extraction method of color moments in each channel of four-color spaces: RGB, HSV, YIQ, and YCbCr, followed by multi-class SVM with four kernels to justify the most appropriate and robust color space against datasets used. It was decided to conduct the evaluation using a test dataset consisting of 1000 images (each class consists of 200 images) in this study. It was decided to use cross-validation with a k-fold value of 10 [17] for the data distribution for both the training and testing phases was selected. The performance evaluation results were obtained by incorporating color features derived from several color spaces and classification utilizing four types of kernels.

Three parameters were used to evaluate the proposed method's performance: precision, recall, and accuracy. These parameters were determined using the multi-class confusion matrix. A confusion matrix is a tool for demonstrating the performance of classification methods by displaying the specifics of successfully classified and incorrectly classified data [25]. The confusion matrix for five courses in this study is presented in Fig. 6. They were Asem Arang (B1), Blekok Warak (B2), Gambang Semarangan (B3), Kembang Sepatu (B4), and Semarangan (B5).

X_{ii} represents the number of images classified correctly as B_i using the proposed method. X_{ij} represents the number of images that should be classed as B_i but are classified as B_j using the proposed method. Otherwise, X_{ji} represents the number of images that should be classed as B_j but are classified

Class		Target Class					
		B_1	B_2	B_3	B_4	B_5	
Predicted Class	B_1	X_{11}	X_{12}	X_{13}	X_{14}	X_{15}	$\rightarrow X_{ij}$
	B_2	X_{21}	X_{22}	X_{23}	X_{24}	X_{25}	$\rightarrow X_{ii}$
	B_3	X_{31}	X_{32}	X_{33}	X_{34}	X_{35}	$\rightarrow X_{ii}$
	B_4	X_{41}	X_{42}	X_{43}	X_{44}	X_{45}	$\rightarrow X_{ji}$
	B_5	X_{51}	X_{52}	X_{53}	X_{54}	X_{55}	$\rightarrow X_{ji}$

Fig. 6. Confusion matrix for Semarang Batik classification with five classes

as B_i using the proposed method. These parameters had values ranging from 0 to 100. If the value was near 1, the proposed method was considered robust and reliable. The following parameters are used in the evaluation [14], [16]:

$$Precision = \frac{X_{ii}}{\sum_{k=1}^n X_{ji}} \times 100, \quad (19)$$

$$Recall = \frac{X_{ii}}{\sum_{k=1}^n X_{ij}} \times 100, \quad (20)$$

$$Accuracy = \frac{\sum_{i=1}^n X_{ii}}{\sum_{i=1}^n \sum_{j=1}^n X_{ij}} \times 100. \quad (21)$$

3. Result and Discussion

The proposed method could produce the highest accuracy only with the color features of the YIQ color space. Several experiments were carried out in order to justify the important features and SVM kernel based on the dataset utilized in this study. The method evaluation was carried out using several feature sets extracted at RGB, HSV, YIQ, and YCbCr color spaces, which fed into SVM classifiers with different kernels: linear, polynomial, sigmoid, and RBF. In each kernel, four feature sets were generated from different color spaces. Therefore, a total of 15 features were tested on the classifier. The classification has been done by 10-fold cross-validation with a dataset consisting of 1000 images (each class consists of 200 images) divided into five classes, namely Asem Arang, Blekok Warak, Gambang Semarang, Kembang Shoes, and Semarang. The method performance was assessed using three evaluation parameters: precision, recall, and accuracy. A comparison of the performance of the Batik Semarang classification method for each feature set using various SVM kernels is summarized in Table 1.

Table 1. Performance comparison of the color features in different color spaces with various kernels of SVM classifier

Color Spaces	Evaluation Parameters	SVM Kernels			
		<i>Linear</i>	<i>Polynomial</i>	<i>Sigmoid</i>	<i>RBF</i>
RGB	Precision	85.5%	92.7%	87.7%	86.6%
	Recall	84.9%	92.6%	86.8%	86.5%
	Accuracy	84.9%	92.6%	86.8%	86.5%
HSV	Precision	92.7%	100%	99.9%	98.8%
	Recall	92.6%	100%	99.9%	98.8%
	Accuracy	92.6%	100%	99.9%	98.8%
YIQ	Precision	100%	100%	100%	100%
	Recall	100%	100%	100%	100%
	Accuracy	100%	100%	100%	100%
YCbCr	Precision	89.3%	98.8%	100%	99.5%
	Recall	86.1%	98.8%	100%	99.5%
	Accuracy	86.1%	98.8%	100%	99.5%

Table 1 shows the varying performance of the proposed method. The features extracted based on RGB color space indicate that they were not discriminatory enough to classify the five classes of Semarang Batik. Since the failures to achieve the highest accuracy values, based on four kernels, only one kernel was polynomial, which achieved the accuracy value of 90%, while other kernels were only up to 80%. The resulting performance based on RGB color space obtained the lowest accuracy value of 84.9% using a linear function kernel, followed by the RBF, sigmoid, and polynomial kernels which achieved an accuracy of 86.5%, 86.8%, and 92.6%. Meanwhile, the HSV and YCbCr color space achieved an accuracy of 1 using polynomial and sigmoid kernels. In HSV color space, the use of kernels other than polynomials achieved an accuracy of more than 0.9, where linear, sigmoid, and RBF reach 92.6%, 99.9%, and 98.8%, respectively. In the YCbCr color space, the method's performance using the linear kernel yielded an accuracy value of 86.1, while in the polynomial and RBF kernel, it achieved 98.8 and 99.5. Furthermore, the YIQ color space achieved the highest performance indicated by the accuracy value achieved of 100% in the implementation of all kernels. It indicated that YIQ was the most suitable color space to be applied to the dataset used in this study and showed that using color features solely was powerful to achieve optimal performance. The details of the classification results for each color space in the dataset consisting of five classes: Asem Arang (AA), Blekok Warak (BW), Gambang Semarangan (GS), Kembang Sepatu (KS), and Semarangan (S) are shown in Fig. 7

RGB																																	
Class		Target Class					Class		Target Class					Class		Target Class					Class		Target Class										
Predicted Class	AA	AA	BW	GS	KS	S	Predicted Class	AA	AA	BW	GS	KS	S	Predicted Class	AA	AA	BW	GS	KS	S	Predicted Class	AA	AA	BW	GS	KS	S						
	AA	183	0	17	0	0		AA	196	0	4	0	0		AA	196	0	4	0	0		AA	196	0	4	0	0	AA	196	0	4	0	0
	BW	0	200	0	0	0		BW	0	200	0	0	0		BW	0	200	0	0	0		BW	0	200	0	0	0	BW	0	200	0	0	0
	GS	22	4	75	0	99		GS	30	0	160	0	10		GS	82	0	101	0	17		GS	66	0	97	0	37	GS	66	0	97	0	37
	KS	0	0	0	200	0		KS	0	0	0	200	0		KS	0	0	0	200	0		KS	0	0	0	200	0	KS	0	0	0	200	0
S	0	0	9	0	191	S	0	0	30	0	170	S	4	0	29	0	167	S	3	0	25	0	172	S	3	0	25	0	172				
Linear					Polynomial					Sigmoid					RBF																		
HSV																																	
Class		Target Class					Class		Target Class					Class		Target Class					Class		Target Class										
Predicted Class	AA	AA	BW	GS	KS	S	Predicted Class	AA	AA	BW	GS	KS	S	Predicted Class	AA	AA	BW	GS	KS	S	Predicted Class	AA	AA	BW	GS	KS	S						
	AA	196	0	4	0	0		AA	200	0	0	0	0		AA	200	0	0	0	0		AA	200	0	0	0	0	AA	200	0	0	0	0
	BW	0	200	0	0	0		BW	0	200	0	0	0		BW	0	200	0	0	0		BW	0	200	0	0	0	BW	0	200	0	0	0
	GS	30	0	160	0	10		GS	0	0	200	0	0		GS	1	0	199	0	0		GS	8	0	188	0	4	GS	8	0	188	0	4
	KS	0	0	0	200	0		KS	0	0	0	200	0		KS	0	0	0	200	0		KS	0	0	0	200	0	KS	0	0	0	200	0
S	0	0	30	0	170	S	0	0	0	0	200	S	0	0	0	0	200	S	0	0	0	0	200	S	0	0	0	0	200				
Linear					Polynomial					Sigmoid					RBF																		
YIQ																																	
Class		Target Class					Class		Target Class					Class		Target Class					Class		Target Class										
Predicted Class	AA	AA	BW	GS	KS	S	Predicted Class	AA	AA	BW	GS	KS	S	Predicted Class	AA	AA	BW	GS	KS	S	Predicted Class	AA	AA	BW	GS	KS	S						
	AA	200	0	0	0	0		AA	200	0	0	0	0		AA	200	0	0	0	0		AA	200	0	0	0	0	AA	200	0	0	0	0
	BW	0	200	0	0	0		BW	0	200	0	0	0		BW	0	200	0	0	0		BW	0	200	0	0	0	BW	0	200	0	0	0
	GS	0	0	200	0	0		GS	0	0	200	0	0		GS	0	0	200	0	0		GS	0	0	200	0	0	GS	0	0	200	0	0
	KS	0	0	0	200	0		KS	0	0	0	200	0		KS	0	0	0	200	0		KS	0	0	0	200	0	KS	0	0	0	200	0
S	0	0	0	0	200	S	0	0	0	0	200	S	0	0	0	0	200	S	0	0	0	0	200	S	0	0	0	0	200				
Linear					Polynomial					Sigmoid					RBF																		
YCbCr																																	
Class		Target Class					Class		Target Class					Class		Target Class					Class		Target Class										
Predicted Class	AA	AA	BW	GS	KS	S	Predicted Class	AA	AA	BW	GS	KS	S	Predicted Class	AA	AA	BW	GS	KS	S	Predicted Class	AA	AA	BW	GS	KS	S						
	AA	188	0	12	0	0		AA	200	0	0	0	0		AA	200	0	0	0	0		AA	200	0	0	0	0	AA	200	0	0	0	0
	BW	0	200	0	0	0		BW	0	200	0	0	0		BW	0	200	0	0	0		BW	0	200	0	0	0	BW	0	200	0	0	0
	GS	66	0	77	0	123		GS	8	0	188	0	4		GS	0	0	200	0	0		GS	5	0	195	0	0	GS	5	0	195	0	0
	KS	0	4	0	196	0		KS	0	0	0	200	0		KS	0	0	0	200	0		KS	0	0	0	200	0	KS	0	0	0	200	0
S	0	0	0	0	200	S	0	0	0	0	200	S	0	0	0	0	200	S	0	0	0	0	200	S	0	0	0	0	200				
Linear					Polynomial					Sigmoid					RBF																		

Fig. 7. Confusion matrix for Semarang Batik classification with various color spaces using different kernels.

In Fig. 7, it can be seen the most errors occur in the Gambang Semarang class, which is classified into the classes of Asem Arang and Semarang, as well as the Gambang Semarang class. This is due to the fact that the primary colors tend to be visually similar. Although the YIQ color space was unsuccessful in discriminating between performance and accuracy, it did achieve an accuracy value of 100%, meaning that there was no misclassified data.

In the following, Table 2 was summarized the performance result of the fabric classification method from several previous studies and the proposed method as well in order to give an overview of the development studies related to various Batik classification methods. Those previous studies used the different methods of features extraction and classification that were implemented against the local datasets. There is no study yet related to the Semarang Batik classification using similar motifs as the dataset used in this study.

Table 2. The summarized of previous studies regarding fabric classification

No.	Approach	Accuracy
1	The combination of GLCM, correlation-based feature selection and KNN [15]	88.9%
2	GLCM and ANN using Backpropagation algorithm menerapkan the Levenberg-Marquardt algorithm training methods [11]	86.1%
3	Features extraction applied MU2ECS-LBP algorithms, while the classification implemented using KNN and ANN [10]	99%
4	Texture features using GLCM and color features based on RGB color space using SVM [16]	97.8%
5	The combination of GLCM and QSVM [17]	94.6%
6	The combination method of Intertwined frame vector and GLCM with the classifiers of KNN and random forest [26]	82.6%
7	Convolutional neural networks with high similarity and large differences in sample size, such as kinky-filling vs. transfer-knot, and broken pick vs. stand-indicator [27]	96%
8	A new texture descriptor called completed local quartet patterns (CLQP) [28]	97.7%
9	The Genetic Algorithm Gabor Faster R-CNN (Faster GG R-CNN) [29]	94.6%
10	Proposed method using color moment based on YIQ colors space and SVM	100%

4. Conclusion

This study aimed to investigate the performance of color features in the classification of Batik, which were divided into five categories: Asem Arang, Blekok Warak, Gambang Semarang, Kembang Sepatu, and Semarang. The color moment was used to extract the features, including the mean, standard deviation, median, minimum, and maximum values. These features were formed based on YIQ color space in each channel; hence 15 features were derived. Subsequently, the features were fed into the SVM classifier using four kernels: linear, polynomial, sigmoid, or RBF, in order to get the appropriate color space. The proposed method was tested on 1000 images, with 200 images in each class. The classification results reveal that the suggested method achieves the best performance, as evidenced by high precision, recall, and accuracy values of 100%. The result indicated the YIQ is the appropriate color space employed against the dataset used in this study because it yielded maximum performance on all kernels of SVM. This study has the potential to develop and improve to generate a smaller number of powerful and

discriminatory features. Therefore, the implementation of the features selection method is required. Consequently, efficiency can be increased while calculation time is reduced.

Declarations

Author contribution. All authors contributed equally to the main contributor to this paper. All authors read and approved the final paper.

Funding statement. This study was supported and funded by Universitas Stikubank (UNISBANK) Semarang Indonesia in 2022 (Grant No. 004/DPPMP/UNISBANK/KONTRAK-PN/VI/2022).

Conflict of interest. The authors declare no conflict of interest.

Additional information. No additional information is available for this paper.

References

- [1] E. Purnamasari, "The Introduction of Classic Batik Motif to the Community Through Game," *SISFORMA*, vol. 4, no. 1, pp. 31–37, Oct. 2017, doi: [10.24167/sisforma.v4i1.1039](https://doi.org/10.24167/sisforma.v4i1.1039).
- [2] UNESCO, "Indonesia Batik : Evaluation of the nominations for inscription on the Representative List of the Intangible Cultural Heritage of Humanity," 2009. [Online]. Available: unesco.org. [Accessed: 17-Feb-2022].
- [3] A. C. Siregar and B. C. Octariadi, "Classification of Sambas Traditional Fabric 'Kain Lunggi' Using Texture Feature," *IJCCS (Indonesian J. Comput. Cybern. Syst.*, vol. 13, no. 4, pp. 389–398, 2019, doi: [10.22146/ijccs.49782](https://doi.org/10.22146/ijccs.49782).
- [4] A. R. Juwita and A. Solichin, "Batik Pattern Identification Using GLCM and Artificial Neural Network Backpropagation," *Proc. 3rd Int. Conf. Informatics Comput. ICIC 2018*, pp. 1–6, 2018, doi: [10.1109/IAC.2018.8780412](https://doi.org/10.1109/IAC.2018.8780412).
- [5] B. R. Lidiawaty, M. Isa Irawan, and R. V. Hari Ginardi, "Image Pattern Verification Based on Seller's Batik Solo Product Name Using SURF As A Texture Based Image Retrieval," *IES 2020 - Int. Electron. Symp. Role Auton. Intell. Syst. Hum. Life Conf.*, pp. 674–679, 2020, doi: [10.1109/IES50839.2020.9231950](https://doi.org/10.1109/IES50839.2020.9231950).
- [6] I. Nurhaida, A. Noviyanto, R. Manurung, and A. M. Arymurthy, "Automatic Indonesian's batik pattern recognition using SIFT approach," *Procedia Comput. Sci.*, vol. 59, pp. 567–576, 2015, doi: [10.1016/j.procs.2015.07.547](https://doi.org/10.1016/j.procs.2015.07.547).
- [7] I. Soesanti and R. Syahputra, "Batik production process optimization using particle swarm optimization method," *J. Theor. Appl. Inf. Technol.*, vol. 86, no. 2, pp. 272–278, 2016. Available at: [Google Scholar](https://scholar.google.com).
- [8] Y. Gultom, A. M. Arymurthy, and R. J. Masikome, "Batik Classification using Deep Convolutional Network Transfer Learning," *J. Ilmu Komput. dan Inf.*, vol. 11, no. 2, pp. 59–66, 2018, doi: [10.21609/jiki.v11i2.507](https://doi.org/10.21609/jiki.v11i2.507).
- [9] I. Nurhaida, H. Wei, R. A. M. Zen, R. Manurung, and A. M. Arymurthy, "Texture fusion for batik motif retrieval system," *Int. J. Electr. Comput. Eng.*, vol. 6, no. 6, pp. 3174–3187, 2016, doi: [10.11591/ijece.v6i6.12049](https://doi.org/10.11591/ijece.v6i6.12049).
- [10] A. H. Rangkuti, A. Harjoko, and A. Putra, "A Novel Reliable Approach for Image Batik Classification That Invariant with Scale and Rotation Using MU2ECS-LBP Algorithm," *Procedia Comput. Sci.*, vol. 179, no. 2019, pp. 863–870, 2021, doi: [10.1016/j.procs.2021.01.075](https://doi.org/10.1016/j.procs.2021.01.075).
- [11] A. Kasim, M. Bakri, and A. Septiarini, "The Artificial Neural Networks (ANN) for Batik Detection Based on Textural Features," in *Proceedings of the Proceedings of the 7th Mathematics, Science, and Computer Science Education International Seminar, MSCEIS 2019, 12 October 2019, Bandung, West Java, Indonesia, 2020*, pp. 1–9, doi: [10.4108/eai.12-10-2019.2296538](https://doi.org/10.4108/eai.12-10-2019.2296538).

- [28] Z. Pourkaramdel, S. Fekri-Ershad, and L. Nanni, "Fabric defect detection based on completed local quartet patterns and majority decision algorithm," *Expert Syst. Appl.*, vol. 198, p. 116827, Jul. 2022, doi: [10.1016/j.eswa.2022.116827](https://doi.org/10.1016/j.eswa.2022.116827).
- [29] M. Chen *et al.*, "Improved faster R-CNN for fabric defect detection based on Gabor filter with Genetic Algorithm optimization," *Comput. Ind.*, vol. 134, p. 103551, Jan. 2022, doi: [10.1016/j.compind.2021.103551](https://doi.org/10.1016/j.compind.2021.103551).